



MODEL Ef/HD  
Full Circle  
Tire Spreader

Installation, Operation  
and Repair Parts  
Information



Branick Industries, Inc. • 4245 Main Avenue • P.O. Box 1937 • Fargo, North Dakota 58103

## **TABLE OF CONTENTS**

---

SAFETY INSTRUCTIONS	1
DEFINITIONS	1
INSTALLATION INSTRUCTIONS	2
OPERATING INSTRUCTIONS	2,3
MAINTENANCE	3
REPAIR PARTS	4-14
REPAIR PARTS LIST	9-14
WARRANTY	15

## **SAFETY INSTRUCTIONS**

---

- NEVER allow unauthorized personnel to operate this product.
- NEVER use this product for anything other than its intended use.
- THOROUGHLY train new employees in the proper use and care of this product.
- PROHIBIT unauthorized personnel from being in shop area while this product is in use.

## **DEFINITIONS**

---

- **CAUTION:** Indicates a potentially hazardous situation, which if not avoided, may result in damage to property or minor personal injury.
- **HAZARD:** A source of potential injury to a person.
- **MAINTENANCE:** Those actions that preserve the correct and proper conditions under which the machine shall be used. This may include adjustment, replacement of wear items, lubrication and cleaning, but not modifications or repair of damage.
- **MAY:** This word is understood to be permissive.
- **MUST:** This word is understood to be mandatory.
- **OPERATION:** The correct and proper use of the machine as described in this manual.
- **SAFETY ALERT SYMBOL:** A symbol that indicates a potential personal safety hazard. It is composed of an equilateral triangle surrounding an exclamation point.
- **SHALL:** This word is understood to be mandatory.
- **SHOULD:** This word is understood to be advisory.
- **WARNING:** Indicates a potentially hazardous situation, which if not avoided, may result in death or serious personal injury.

## CAUTION

- ◆ Before using this product, read and fully understand the operating instructions and all decals on the product. This is necessary to prevent injury to the operator and damage to the product.
- ◆ This product is intended to be used to spread tire casings for inspection and/or repair only.
- ◆ Keep fingers and hands clear of all hooks and mechanisms during operation.
- ◆ Do not use this product if it is visibly worn, distorted or damaged.
- ◆ Always wear appropriate eye protection.

## WARNING

- ◆ Keep feet clear of the tire lift when raising and lowering tire.
- ◆ All personnel must be clear of the spread arms during operation.

### **INSTALLATION**

---

- 1) Position the Model eF/HD on a solid level floor leaving a minimum of 12 inches of clearance from rear and 24 inches of clearance from sides. The eF can be bolted down if desired using the four holes in bottom of frame.
- 2) Attach the loose spread arm spring to spread arm. Refer to the other spread arm for proper spring location.
- 3) Attach the lift cradle to the lower lift arms.
- 5) Install a 1/4 NPT quick coupler nipple (not provided) into the air filter located on frame column. Use 1/4 inch air hose with 100 p.s.i. minimum.

### **OPERATION**

---

- 1) Roll tire onto lift cradle, and while balancing the tire with hands, step on left foot valve to raise tire just above inner bead hooks. Release lift valve to allow cradle to lower to floor and tire hanging on inner bead hooks.
- 2) While keeping tire on inner bead hooks, step on center foot valve to spread and fully engage all four hooks on inner bead of tire.
- 3) Grasp both outer bead hook arms by the handles and pull to center of tire. Push forward and allow bead hooks to engage outer bead of tire. **Make certain all hooks are securely engaged with tire beads before spreading tire.**
- 4) To spread the tire, step on right foot valve to obtain desired spread. Tire can now be rotated and inspected.



## **WARNING**

- ◆ **Do not release the inner bead hooks (center valve) until the outer bead hooks have been released (right valve) and removed from tire.**

- 5) To remove tire, release spread arm control valve (right valve) and remove outer bead hook.
- 6) Release pressure on inner bead hooks by stepping on diameter control valve (center valve).
- 7) With tire hanging on inner hooks, raise lift cradle (left valve) up to contact tire. While holding onto tire, raise tire slightly above inner bead hooks and lean tire outward and release pressure on lift valve to lower tire to floor.

## ***MAINTENANCE***

---

**MONTHLY** – Put a few ounces of 10 or 20 weight oil in all cylinders.

Lubricate all moving parts (bolts, hinges, rollers, etc.) with a lubricating oil.

Grease cylinder bearings through the grease zerk fittings. Apply some grease to the races of the bearings also.

**REPAIR PARTS**

---

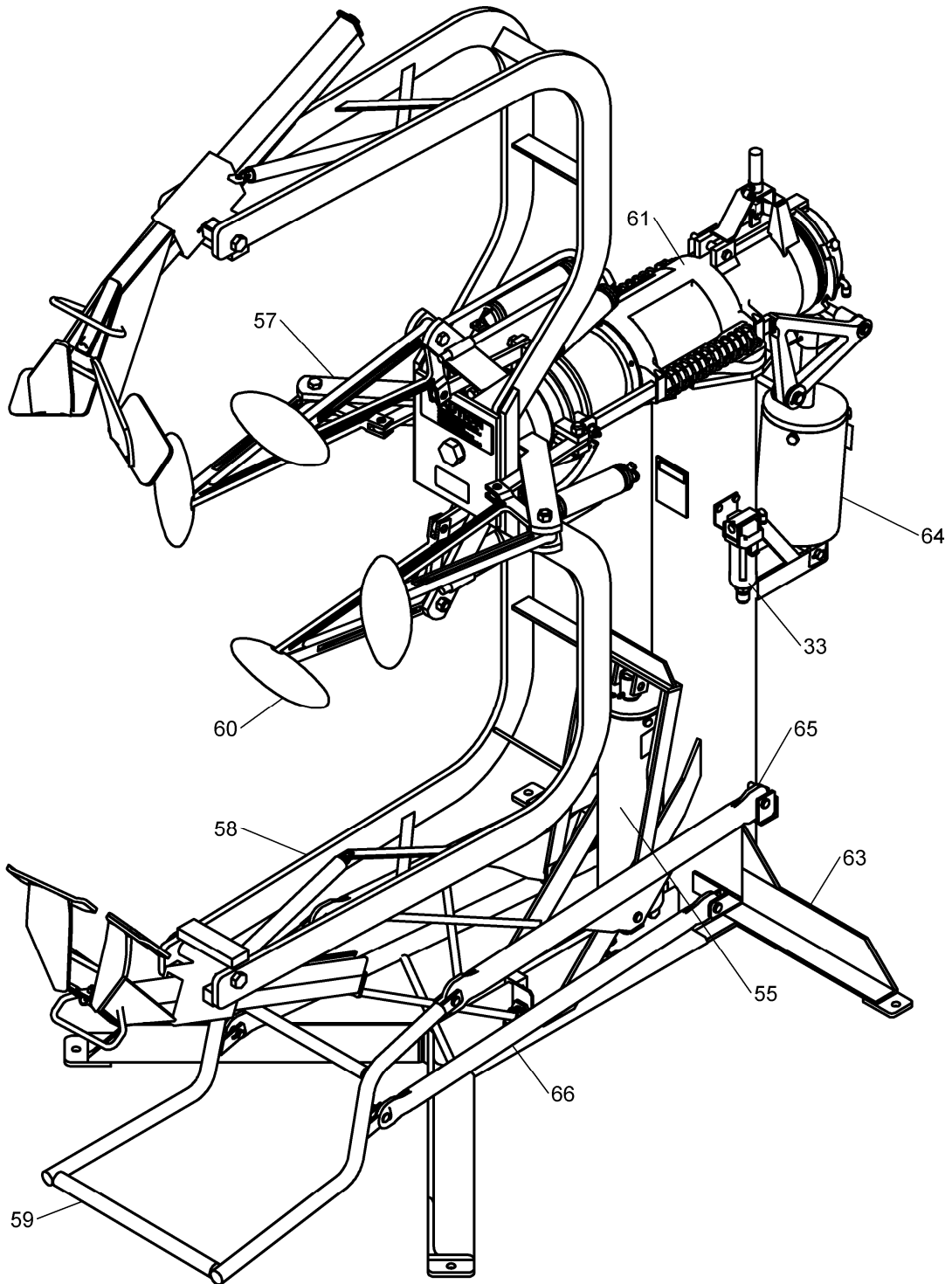

**Model HD.EF General Assembly**

See parts list on page 9 & 10

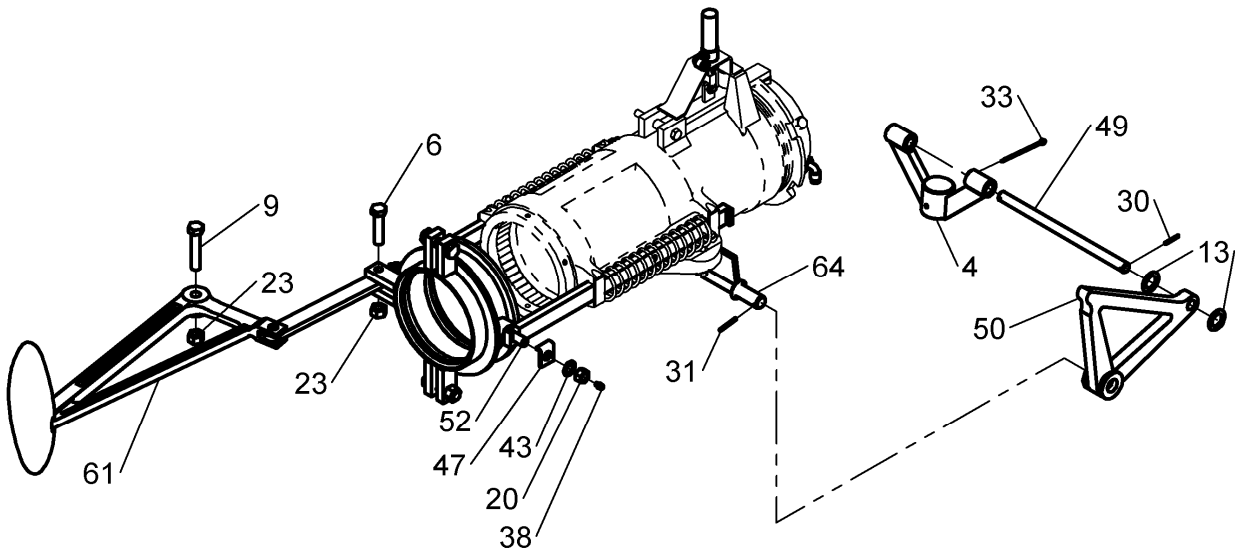

## Diameter Arms & Linkage

See parts list on page 9 & 10

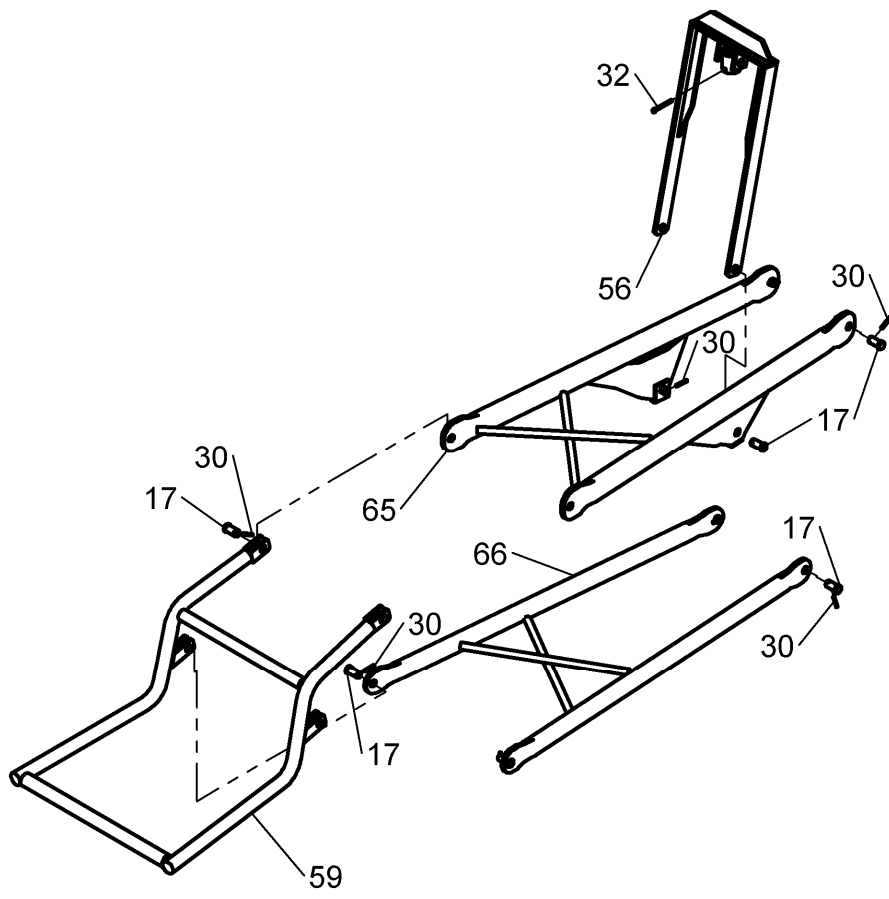

### Lift Cradle Assembly

See parts list on page 9 & 10



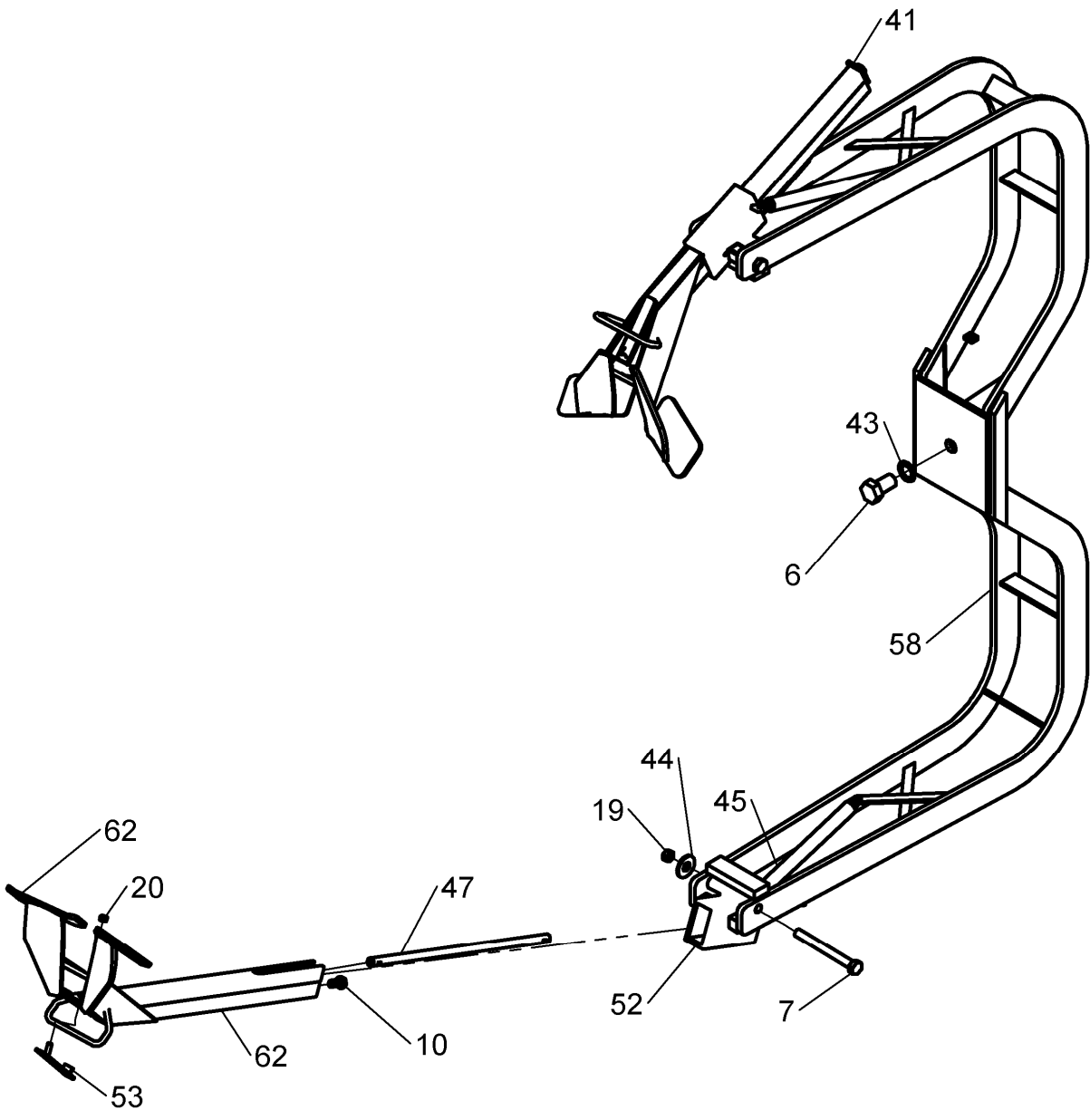

**Spread Arms Assembly**  
See parts list on page 9 & 10

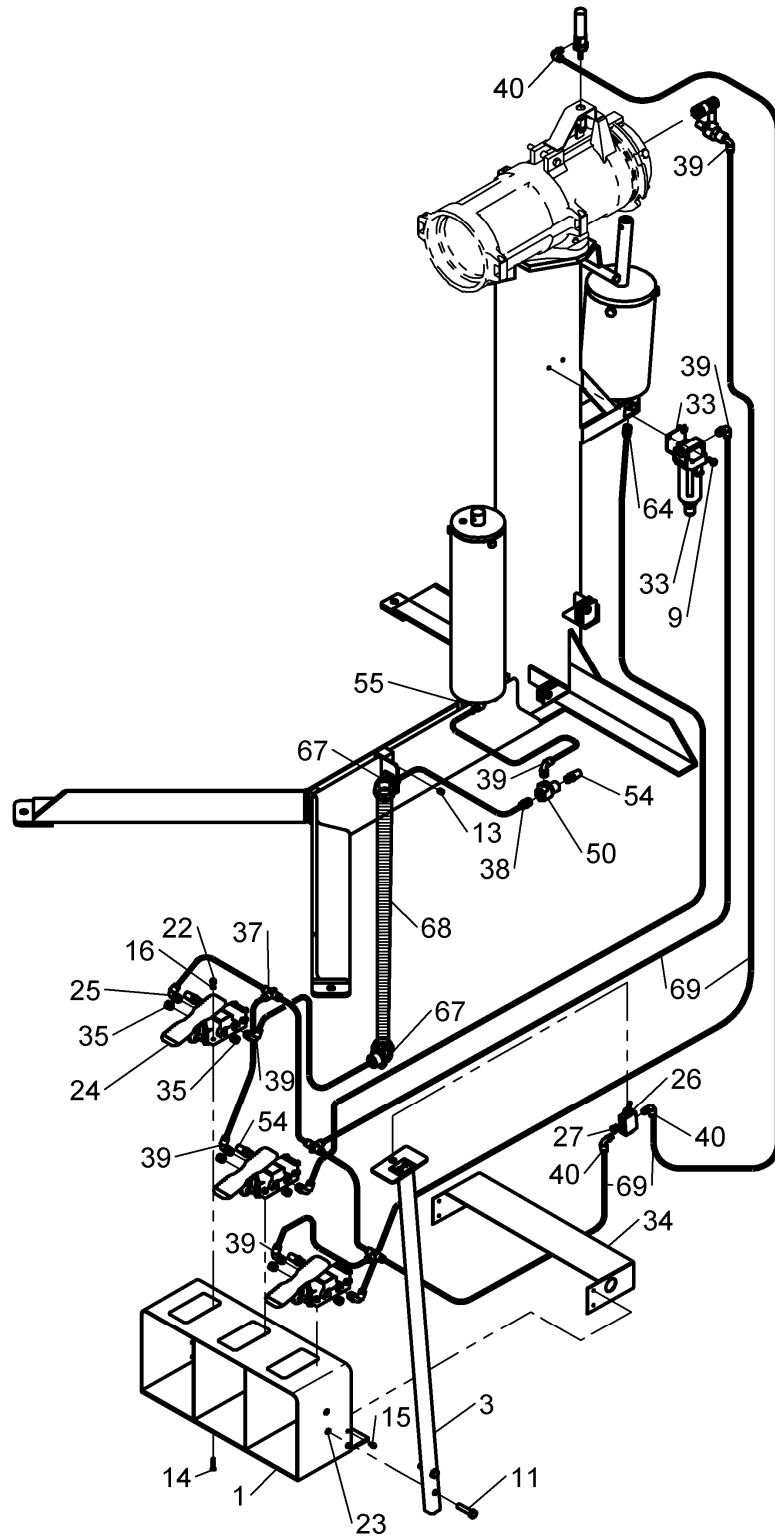

## Pneumatics

See parts list on page 9 & 10

**REPAIR PARTS LIST**

ITEM	QTY	PART NO.	DESCRIPTION
1	1	03-0048	WELD, FOOT GUARD
2	1	03-0052	WELD, FITTING MOUNT
3	1	03-0219	WELD, VALVE MOUNT
4	1	03-0363	CONNECTOR, HDEF DIA. CYL.
5	6	028-006	SCREW, 1/2 X 2 NC H.H.C
6	1	028-017	SCREW, 1 X 1.75 N.C H.H.C
7	2	028-024	SCREW, 5/8 X 6 N.C H.H.C
8	4	028-089	SCREW, 1/2NC X 2-1/2 HHC
9	2	028-132	SCREW, 1/4-20 x 1/2 HHC
10	2	028-159	SCREW, 1/2-13 X 1 HHC
11	2	028-289	SCREW, 3/8-16 X 1-1/2 HHC
12	4	039-002	BUSHING, 3/4 MACHINE
13	1	50-0006	SCREW, 5/16-18 SS
14	12	50-0041	SCREW, #8-32 X 1 CSK HD MACH
15	4	50-0090	SCREW, #8-32 X 3/8 SHH TAPPING
16	12	52-0006	WASHER, #8 INT TOOTH LOCK
17	10	54-0003	PIN, 1/2" x 1" CLEVIS
18	2	055-010	NUT, 1/2-20 HEX JAM
19	2	055-011	NUT, 5/8 HEX
20	2	055-023	NUT, 5/16-18 PREV TORQ LOCK
21	10	055-058	NUT, 1/2-13NC BI-WAY LOCK
22	12	055-082	NUT, #8-32 NYLON LOCK
23	2	055-103	NUT, 3/8-16 SERR HEX FLG
24	3	60-0009	VALVE, TREADLE, 4-WAY
25	1	60-0010	FITTING, 1/4 TUBE ELBOW (ORIFICED)
26	1	60-0046	VALVE, TOGGLE
27	1	60-0174	FITTING, 1/8 NPT BREATHER VENT
28	4	061-005	PIN, 1/8 X 1 SPRING
29	2	061-006	PIN, 1/8 X 1-1/4 SPRING
30	10	061-009	PIN, 5/32 X 1 SPRING
31	1	061-166	PIN, COTTER
32	1	061-013	PIN, 5/32 X 1.75 COTTER
33	1	64-0001	FILTER W/BACKET
34	1	72-0021	GUARD, AIRLINE
35	7	096-004	FITTING, 1/4 NPT HSH PLUG
36	2	096-010	ZERK, 3/16" DRIVE
37	3	096-339	FITTING, UNION TEE (1/4 TUBE)
38	1	096-340	FITTING, 1/4NPT X 1/4 TUBE, STR.
39	8	096-342	FITTING, 1/4 TUBE ELBOW
40	3	096-346	FITTING, 1/8 NPT X 1/4 TUBE, 90°

<b>ITEM</b>	<b>QTY</b>	<b>PART NO.</b>	<b>DESCRIPTION</b>	
41	2	101-197	PLATE	
42	2	108-006	WASHER, 1/2 INTENAL LOCK	
43	1	108-012	WASHER, 1" INT. LOCK	
44	2	108-022	WASHER, 5/8 WROUGHT	
45	2	110-011	SPRING, TENSION	
46	2	111-030	BRACKET, INSIDE ARM	
47	2	110-200	SPRING, SLEEVE	
48	1	149-112	EQUALIZER ROD	
49	2	157-003	WELDMENT, BELL CRANK	
50	2	190-085	VALVE, QUICK EXHAUST	
51	2	281-004	1.25 ROLLER	
52	2	446-006	BEAD HOOK SOCKET	
53	2	876-002	SPRING CONNECTOR	
54	5	885-035	MUFFLER, 1/4 NPT	
55	1	900-016	LIFT CYLINDER W/ CUP	
56	1	900-022	YOKE ASSEMBLY	
57	1	900-028	SPREAD ARM CYLINDER ASSY.	
58	1	900-033	HEAD, SPREAD ARM W/ EXTENSION	
59	1	900-035	LIFT CRADLE ASSY	
60	4	900-036	DIAMETER ARM ASSEMBLY	
61	1	900-037	HD/EF TIRE SPREADER	
62	2	900-040	BEAD HOOK ASSY.	
63	1	900-041	BASE & COLUMN	
64	1	900-043	DIAMETER ARM CYLINDER ASSEMBLY	
65	1	950-046	UPPER ARM ASSEMBLY	
66	1	950-061	LOWER ARM ASSEMBLY	
67	2	980-085	CONNECTOR, 3/4-45° CONDUIT	
68		B40-003	CONDUIT, 3/4 FELX	
69		D20-007	TUBE, 1/4 OD (YELLOW)	

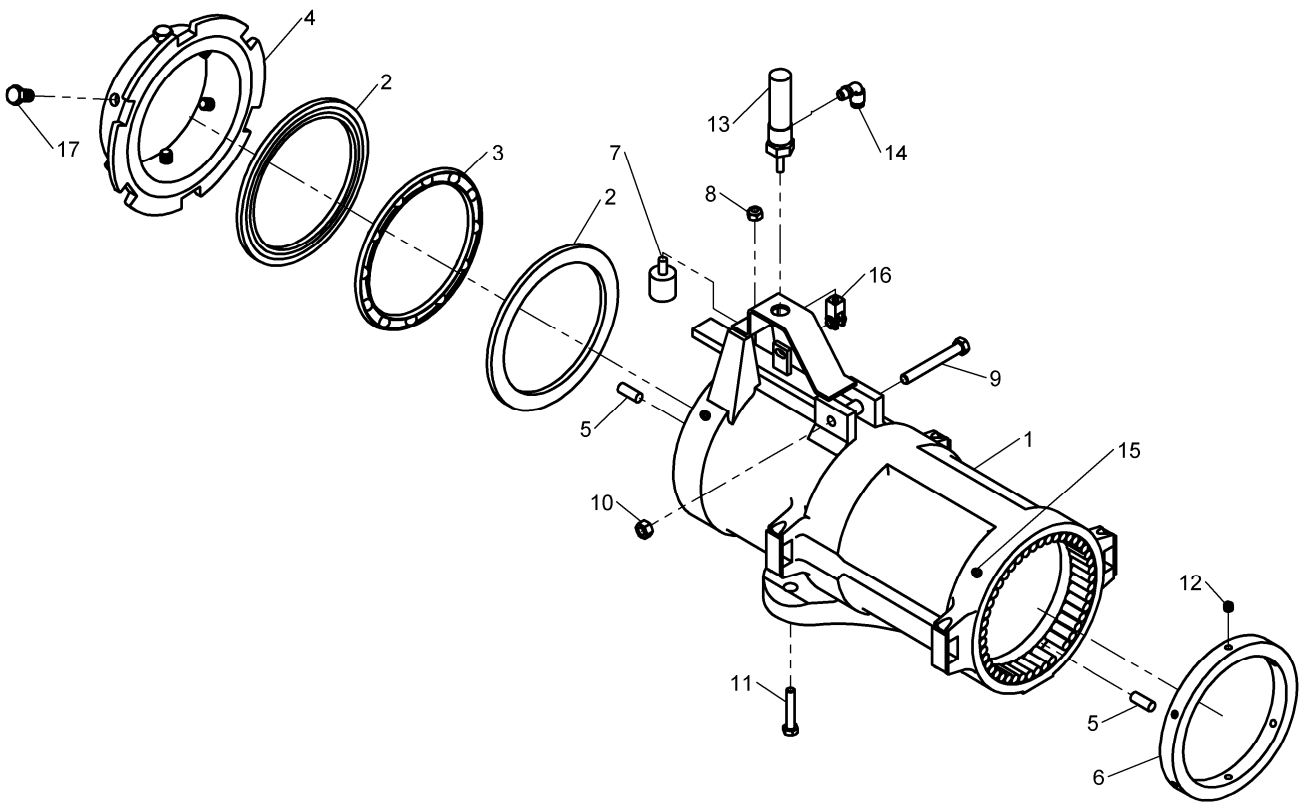

### Housing Assembly (900-037)

ITEM	QTY	PART NO.	DESCRIPTION
1	1	950-050	HOUSING SUB ASSY.
2	2	107-005	BALL RACE
3	1	107-043	THRUST BEARING RETAINER
4	1	489-003	REAR COLLAR
5	98	281-001	ROLLER BEARING
6	1	489-002	FRONT COLLAR
7	1	10-0018	VIBRATION MOUNT
8	1	055-145	5/16-18 NYLON LOCK NUT
9	1	028-022	3/8-16 X 3 HHC SCREW
10	1	055-123	3/8-16 NC HEX NUT
11	2	028-016	5/16-18 X 1/3/4 HHCS SCREW
12	12	028-004	5/16 X 1/4 SOC SET SCREW
13	1	63-0014	AIR CYLINDER
14	1	096-346	1/8 NPT X 1/4 TUBE ELBOW FITTING
15	2	096-008	GREASE ZERK
16	1	53-0013	CYLINDER CLEVIS
17	6	028-005	7/16-14 X 3/4 HHC SCREW

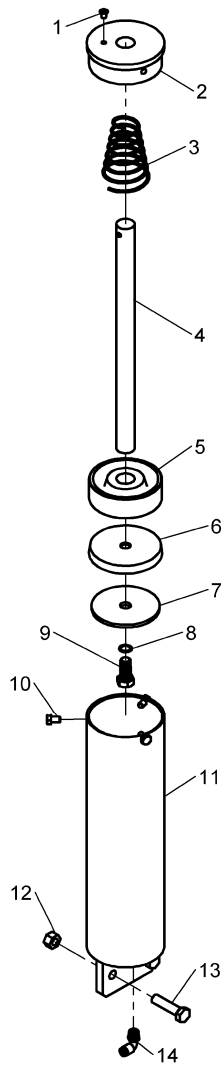

### Lift Cylinder Assembly (900-016)

ITEM	QTY	PART NO.	DESCRIPTION
1	1	006-004	1/4 CAP PLUG
2	1	098-005	LIFT CYLINDER COVER PLATE
3	1	110-007	LIFT CYLINDER SPRING
4	1	149-011	LIFT PISTON ROD
5	1	051-026	LIFT PISTON
6	1	041-295	4" PISTON CUP
7	1	101-296	CUP RETAINER
8	1	167-240	14mm GASKET
9	1	028-239	9/16-12 X 1/1/4 HHC SCREW
10	3	028-280	5/16-18 X 1/2 HHC SCREW
11	1	005-030	LIFT CYLINDER TUBE
12	2	055-058	1/2-13 NC BI-WAY LOCK NUT
13	2	028-006	1/2 X 2 NC HHC SCREW
14	1	096-342	1/4 TUBE ELBOW FITTING

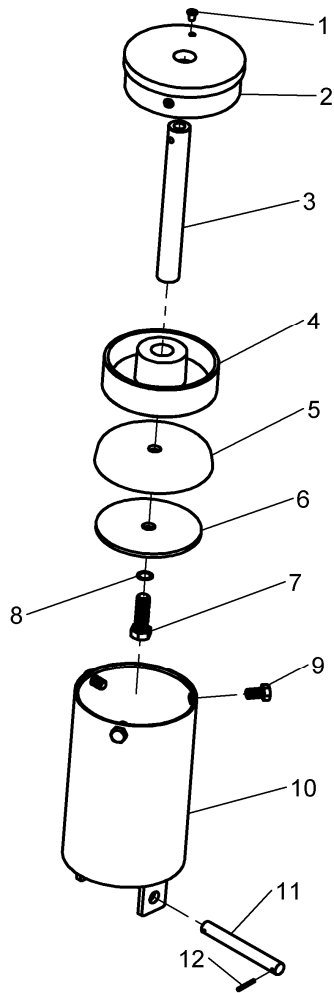

### Diameter Arm Cylinder Assembly (900-043)

ITEM	QTY	PART NO.	DESCRIPTION
1	1	006-004	1/4 CAP PLUG
2	1	264-001	DIA. ARM CYLINDER
3	1	104-002	PISTON SHAFT
4	1	051-016	5/16" PISTON
5	1	041-009	5/16" PISTON CUP
6	1	101-033	PISTON PLATE
7	1	028-013	9/16-12 X 1/3/4 HHC SCREW
8	1	167-240	14 mm GASKET
9	3	028-005	7/16-14 X 3/4 HHC SCREW
10	1	030-006	CYLINDER TUBE
11	1	149-020	DIA. CYLINDER ROD
12	2	061-005	1/8 X 1 SPRING PIN

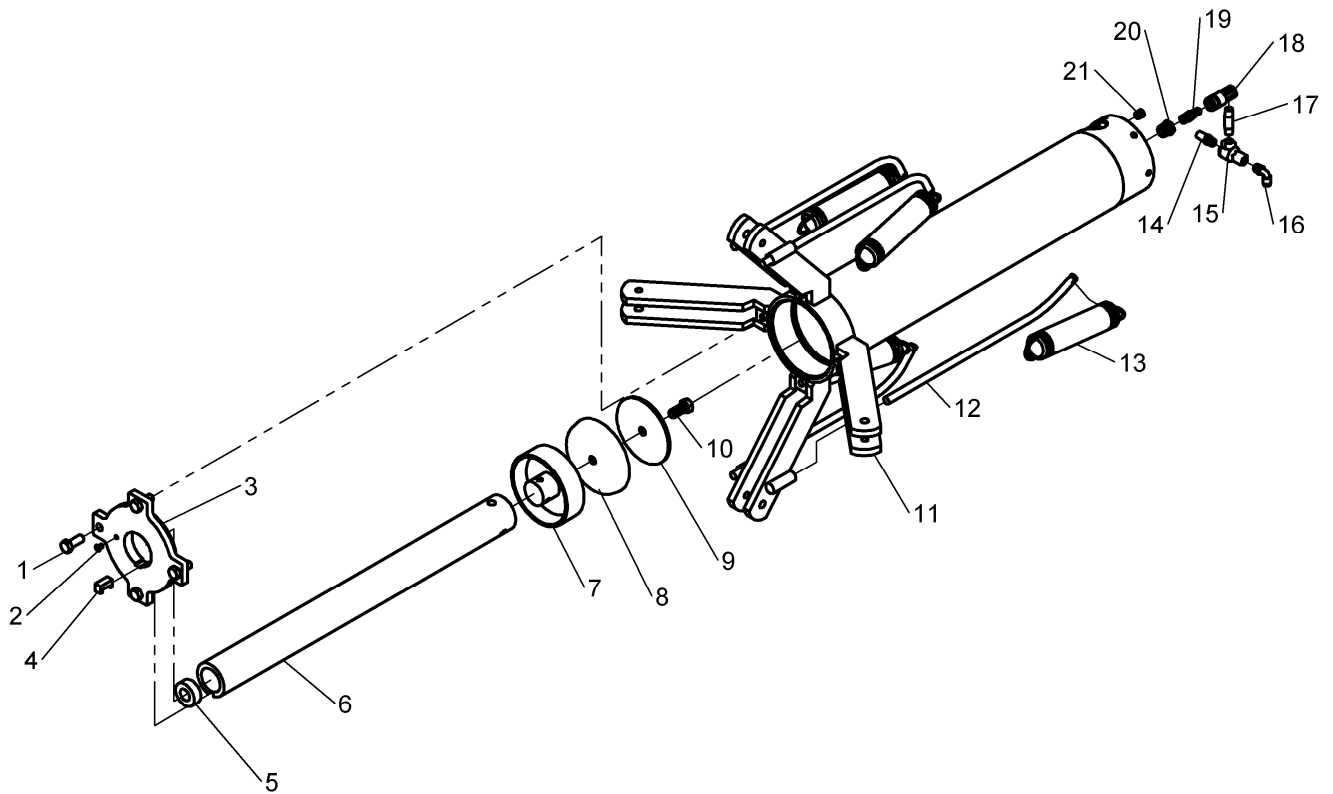

### Spread Cylinder Assembly (900-028)

ITEM	QTY	PART NO.	DESCRIPTION
1	4	028-034	1/2-13 X 1/1/4 HHC SCREW
2	1	006-004	1/4 CAP PLUG
3	1	098-004	COVER PLATE
4	1	251-002	KEY
5	1	108-011	PISTON ROD WASHER
6	1	149-008	PISTON KROD
7	1	051-006	SPREAD ARM PISTON
8	1	041-009	5/1/4 PISTON CUP
9	1	101-033	PISTON PLATE
10	1	028-239	9/16-12 X 1/1/4 HHC SCREW
11	1	103-009	SPIDER ARM
12	4	149-021	RETURN SPRING ROD
13	4	110-004	TENSION SPRINGS
14	1	885-035	1/4 NPT MUFFLER
15	1	190-085	QUICK EXHAUST VALVE
16	1	096-342	1/4 TUBE ELBOW FITTING
17	1	096-007	2" PIPE NIPPLE
18	1	034-027	QUICK COUPLER
19	1	096-170	1/4 TRU-FLATE NIPPLE
20	1	039-008	1/2 TO 1/4 PIPE BUSHING
21	1	096-004	1/4 NPT HSH PLUG



### COMMERCIAL WARRANTY

This product is warranted by BRANICK INDUSTRIES, INC. to the original user-owner against defective materials or workmanship for a period of one year from the date of delivery. During the warranty period, product found to be defective will be repaired or replaced at, BRANICK INDUSTRIES, INC.'s option, without charge. The product must be returned, with prior approval, transportation charges prepaid and with proof of original delivery date, to BRANICK INDUSTRIES, INC., 4245 Main Ave., Fargo, North Dakota 58107. The repaired or replacement product will be returned with transportation charges prepaid by Branick.

This warranty does not cover defects in the product caused by ordinary wear and tear, abuse, misuse, overloading, accident (including shipping damage), improper maintenance, alteration, or any other cause not the result of defective materials or workmanship.

REPAIR OR REPLACEMENT IS THE EXCLUSIVE REMEDY FOR DEFECTIVE PRODUCT UNDER THIS WARRANTY. THIS WARRANTY IS EXPRESSLY IN LIEU OF ALL OTHER WARRANTIES, INCLUDING ANY IMPLIED WARRANTY OF MERCHANTABILITY OR ANY IMPLIED WARRANTY OF FITNESS FOR A PARTICULAR PURPOSE OF THIS PRODUCT. BRANICK INDUSTRIES, INC. SHALL NOT BE LIABLE FOR ANY CONSEQUENTIAL OR INCIDENTAL DAMAGES.

*BRANICK INDUSTRIES, INC. reserves the right to make changes in the design or construction of our products without obligation to incorporate such changes in products already sold and without notice.*

Service parts, warranty, and regular repair service for products are available from Branick authorized distributors or from:

BRANICK INDUSTRIES, INC.  
4245 Main Ave.  
Box 1937  
Fargo, North Dakota 58107  
701/281-8888

***Branick***®  
**INDUSTRIES, Inc.**